

PIBV2A Post Indicator and Butterfly Valve Supervisory Switch



Specifications

| | |
|------------------------------|---|
| Contact Ratings: | 10A @ 125/250 VAC 2.5 A @ 24 VDC |
| Cover Tamper Switch Ratings: | 5 A @ 125/250 VAC; 2.5 A @ 24 VDC |
| Dimensions: | 8¼" H X 3½" W X 3¼" D |
| Maximum Stem Extension: | 3 ⁵ / ₂ " |
| Operating Temperature Range: | 0°C - 49°C (32°F - 120°F) |
| Shipping Weight | 2 lbs. |
| Enclosure Rating: | NEMA Type 3R when mounted with the actuator vertical (cover on top) as tested by Underwriters Laboratories, Inc. (PIBV2A is ULC approved) |

Important

Please Read Carefully and Save

This instruction manual contains important information on the installation and operation of supervisory switches. Purchasers who install supervisory switches for use by others must leave this manual or a copy of it with the user. These instructions apply to Safe Signal switches for post indicator and butterfly type valves. Read all instructions carefully before beginning installation.



Do NOT use this switch in explosive or potentially explosive atmospheres. Do NOT leave unused wires exposed.

All supervisory switch installations must comply with local codes and ordinances and the requirements of the authority having jurisdiction. Additional information is available in National Fire Protection Association standards NFPA 13, 13D, 13R, 71, and 72. The connection of supervisory switches to alarm control units is governed by CAN/ULC-S524-M91, standard for the Installation of Fire Alarm Systems.

General Installation Considerations

1. Model PIBV2A is designed for installation in a ½" NPT tapped hole and located so that the actuating lever of the switch engages the target or flag of the valve . The switch actuating lever is spring loaded against the flag or target of the valve and is released when the valve moves toward the closed position from the fully open position. The switch is factory set to indicate an alarm condition when the target and lever move in the direction toward the conduit entry hole when the valve closes, but can be reversed if the installation demands (refer to Section 4).

Figure 1:

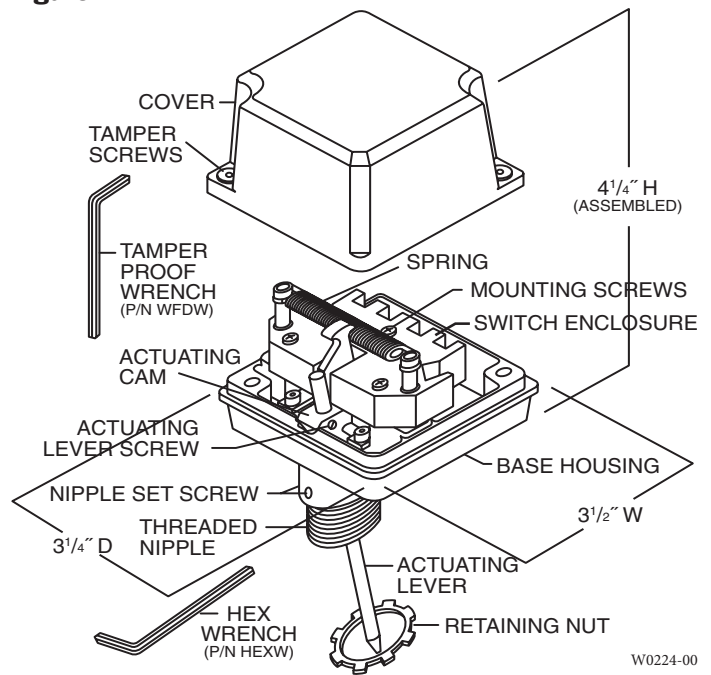

2. Model PIBV2A is equipped with a removable ½" NPT pipe nipple which is locked in place with two set screws. A hex wrench is provided for this feature. The PIBV2 also includes an adjustable length actuating lever.
3. The cover is secured with two tamper resistant screws which require a special key to remove. One key is included with each supervisory switch. Replacement and additional keys are available (Part No. WFDW).

Figures 2A and 2B:

Rising Flag

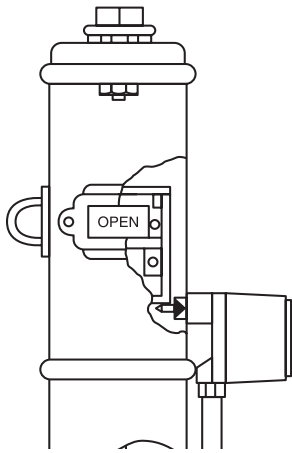

Falling flag

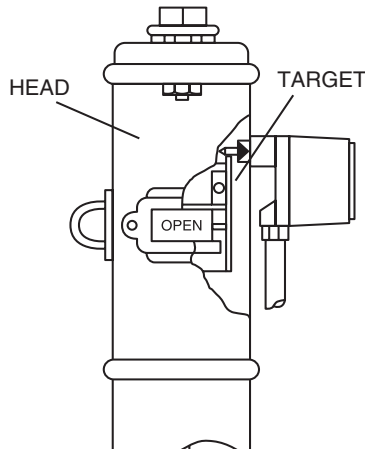

Section 1

Installation Instructions For Post Indicator Valves

1. There are two types of post indicator valves - rising flag and falling flag. In a rising flag installation, the PIBV2A mounts below the target assembly, as shown in Figure 2A. Closing the valve raises the target assembly and releases the actuating lever on the PIBV2A. In a falling flag installation, the PIBV2A mounts above the target assembly (Figure 2B). Closing the valve lowers the target assembly and releases the actuating lever on the PIBV2A.
The PIBV2A is set for falling flag installation. If a rising flag operation is desired, it is necessary to reverse the action of the switch (See Section 4).
2. If the post indicator valve is predrilled with $\frac{1}{2}$ " NPT mounting hole, remove the plug and go to step 6. If the post indicator valve is NOT equipped with a $\frac{1}{2}$ " NPT mounting hole, it will be necessary to drill and tap the hole.
3. Position the valve in the fully open position ("OPEN" should appear in the window) and remove the head and target assembly. In doing so, ensure that the assembly can be reinstalled with its original adjustment.
4. (a) In a falling flag installation (flag lowers as valve is closed), measure the distance from the bottom of the head to the upper surface of the target that will contact the actuating lever of the PIBV2A. Add $\frac{3}{32}$ " to this measurement and mark the outside of the housing at that location. Drill with a $2\frac{3}{32}$ " drill bit and tap a $\frac{1}{2}$ " NPT thread.
(b) In a rising flag installation (flag rises as valve is closed), measure the distance from the bottom of the head to the lower surface of the target that will contact the actuating lever. Subtract $\frac{3}{32}$ " to this measurement and mark the outside of the housing at that location. Drill with a $2\frac{3}{32}$ " drill bit and tap a $\frac{1}{2}$ " NPT thread.
5. Replace the head and target assembly.
6. Screw the locknut onto the threaded nipple which is supplied with the PIBV2A.
7. Screw the nipple hand tight into the $\frac{1}{2}$ " hole in the valve and

tighten the locknut against the housing to secure the nipple in position.

8. Insert a probe into the hole through the nipple to measure the distance from the open end of the nipple to the desired position on the target assembly. Subtract $\frac{5}{8}$ " from the distance and set the length of the actuating lever of the PIBV2A from the end of the enclosure to this distance. Tighten the screw which holds the actuating lever.
NOTE: Place cover over PIBV2 to ensure that actuating lever does not interfere with cover. If actuating lever interferes with cover, remove lever and break off additional length at break-away point. Repeat step 8 to re-install actuator lever. Refer to Figure 7.
9. Close the valve 3 to 4 revolutions.
10. Install the PIBV2A onto the nipple and orient the conduit entry down (See Figure 4). Apply pressure to the PIBV2A and lock the set screws to secure the nipple to the PIBV2A.
11. Slowly open the valve to its fully open position. The switch should trip as the valve opens, but not force the actuating lever against the nipple when fully open. To check for this condition, open the valve fully and depress the top of the actuating cam to stretch the actuating spring further. There should be some additional movement available. If no movement is available, damage may occur to the PIBV2A actuator lever. It will be necessary to adjust the flag location by removing the head and turning the handle while the valve stem is disengaged (refer to the valve manufacturer.)
12. After checking the fully open position to ensure adequate clearance, close the valve slowly until the PIBV2A contacts trip. The switches must trip within $\frac{1}{5}$ of the full travel distance of the valve.
13. If the PIBV2A does not change states within $\frac{1}{5}$ of the length of travel, it may be necessary to adjust the flag up or down by removing the head and turning the handle (refer to the valve manufacturer.)

Section 2

Installation Instructions For Butterfly Valves

(See Figure 3)

1. Remove the $\frac{1}{2}$ " NPT plug from the gear housing.
2. Loosen 2 set screws that hold the nipple on the PIBV2A and remove the nipple.
3. Screw the locknut onto the nipple.
4. Screw the nipple into the $\frac{1}{2}$ " NPT hole and hand tighten. Tighten the locknut firmly to the housing to secure the nipple.
5. Open the valve fully and close the valve approximately 3 revolutions, noting which direction the target moves.
6. Retract the actuating arm and install PIBV2A onto the nipple, orienting the PIBV2A to trip the switch as the valve closes. If the conduit entry is on the wrong side, it will be necessary to reverse the action of the switch (see Section 4). Apply pressure to PIBV2A and tighten set screws to secure the assembly.
7. Slide the actuating arm into the valve until it bottoms on the flag, but do not tighten the screw which holds the actuating

Figure 3:

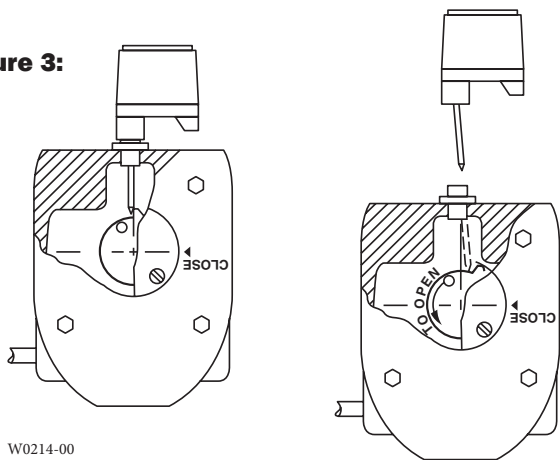

W0214-00

lever.

NOTE: Place cover over PIBV2 to ensure that actuating lever does not interfere with cover. If actuating lever interferes with cover, remove lever and break off additional length at breakaway point. Refer to Figure 7.

8. Open the valve to the full open position and tighten screw to hold actuating arm in position. (Actuating arm length will adjust slightly as valve is opened.) Check to ensure that in the full open position the actuating arm is not resting on the nipple. Do this by depressing the actuating cam to further stretch the spring, ensuring that more travel is available when the valve is open. If there is no travel, damage may occur to PIBV2A actuating arm. Some slight alteration of the valve stop setting may be necessary to ensure that no damage occurs.
9. Carefully close valve and note the number of handle revolutions until the switch trips. The switch must trip within $\frac{1}{5}$ of the total travel range of the valve.

Section 3

General Installation Instructions

1. Installation Positions

Figure 4:

The following are examples of acceptable mounting positions:

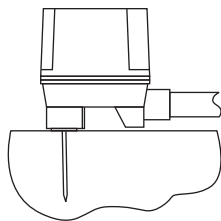

Actuator Vertical (Down)

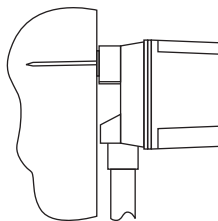

Actuator Horizontal

The following mounting position is not acceptable:

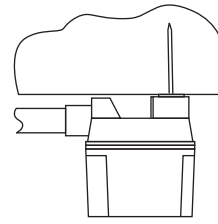

Actuator Vertical (Pointing Up)

2. Ground Screw — A ground screw is provided with all supervisory switch models. When grounding is required, clamp wire with the screw in hole located near conduit entrance.
3. Wiring — See Figure 6, Page 4.

Section 4

Reversing The Action Of PIBV2A

1. Loosen the 3 phillips screws on the top of the black switch enclosure so that the switch enclosure is loose and free to move (see Figure 5).
2. Slide the switch enclosure away from the conduit entry toward the actuating pivot arm as far as possible and tighten the 3 screws to secure the enclosure. (Ensure that switch enclosure remains oriented away from the conduit entry as screws are tightened.)
3. Grasp the spring at the center and lift it over the actuating cam so that it seats on the opposite side of the actuator (see Figure 5).

Figure 5:

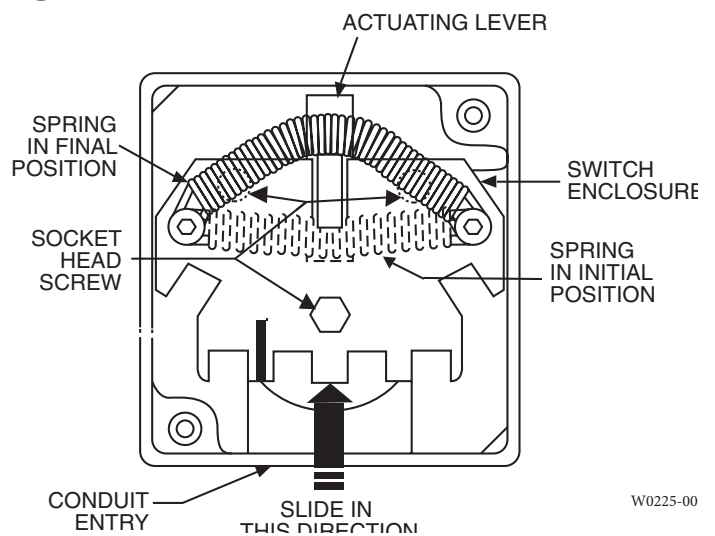

W0225-00

Figure 6:

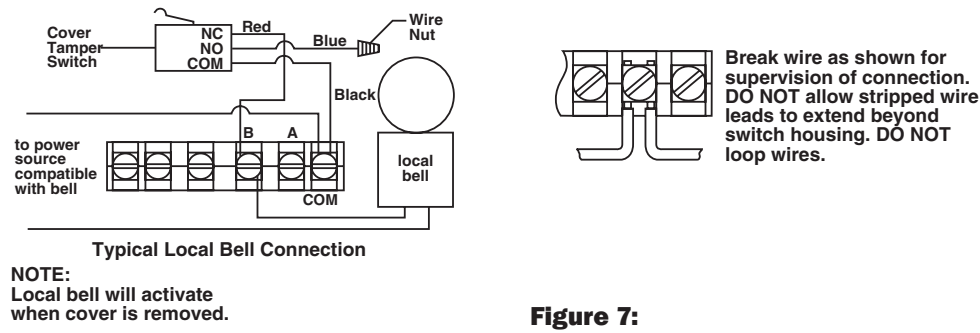
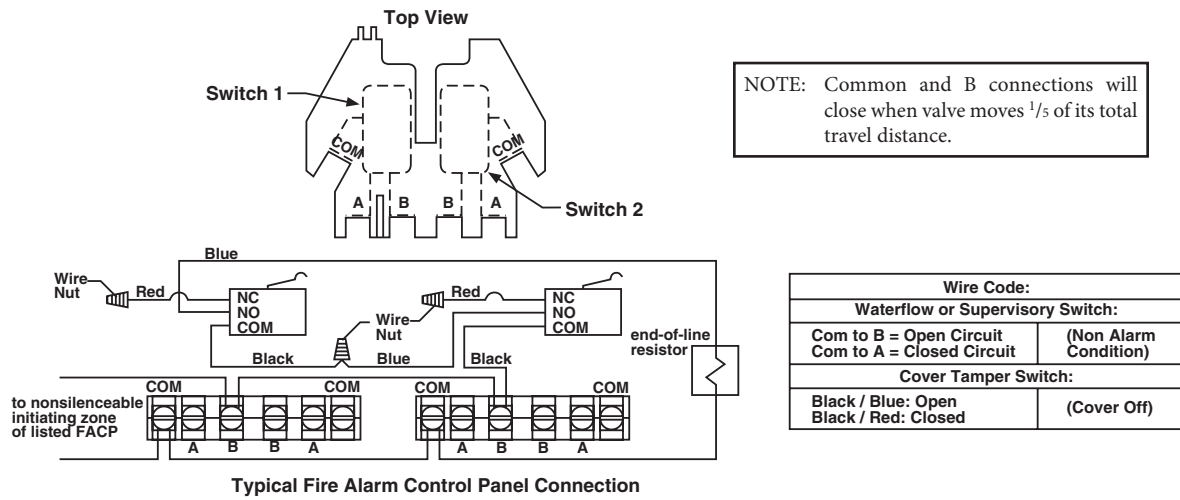
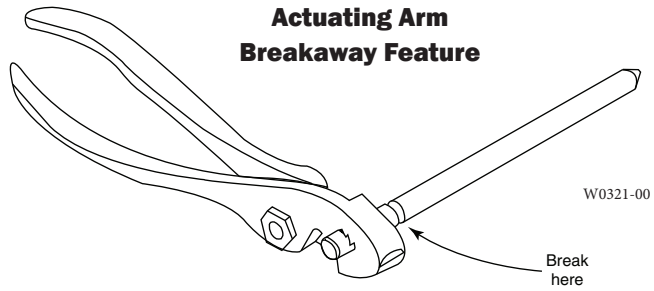

Figure 7:

W0156-00



⚠ WARNING

The Limitations of Supervisory Switch Alarm Devices

1. Alarms generated by the activation of the actuating lever may not be received by a central station if telephone or other communication lines to the alarm device are out of service, disabled, or open.
2. Supervisory switch alarm devices have a normal service life of 10-15 years.
3. Supervisory switches are not a substitute for insurance. Building owners should always insure property and lives being protected.

THREE-YEAR LIMITED WARRANTY

SAFE SIGNAL warrants that the equipment herein shall conform to said descriptions as to all affirmation of fact and shall be free from defects of manufacture, labeling, and packaging for a period of three (3) years from the invoice date to the original purchaser, provided that representative samples are returned to SAFE SIGNAL for inspection. Upon a determination by SAFE SIGNAL that a product is not as warranted, SAFE SIGNAL shall, at its exclusive option, replace or repair said defective product or parts thereof at its own expense except that Purchaser shall pay all

shipping, insurance, and similar charges incurred in connection with the replacement of the defective product or parts thereof. This Warranty is void in the case of abuse, misuse, abnormal usage, faulty installation, or repair by unauthorized persons, or if for any other reason SAFE SIGNAL determines that said product is not operating properly as a result of causes other than defective manufacture, labeling, or packaging.