

# PSP1A Plug-in Special Purpose Supervisory Switch



U. S. Patent Number: 6,037,867

## Specifications

|                            |  |
|----------------------------|--|
| Dimensions:                | 4.73" L x 2.94" W x 2.21" D (12 cm L x 7.5 cm W x 5.6 cm D)<br>With bracket – 8.5" L (21.5 cm L) |
| Weight:                    | 1.7 lbs. (.774kg)  |
| Enclosure Rating:          | Cast-aluminum rain-tight outlet box, Indoor/Outdoor NEMA 3                                       |
| Tamper Protection:         | Cover tamper switch and tamper-proof cover screws  |
| Operating Voltage:         | 6/12/24 volts AC/DC  |
| Maximum Operating Current: | 250 mA   |
| Operating Temperature:     | -20°C to 65°C (-4°F to 149°F)  |

## Important

Please Read Carefully and Save

This instruction manual contains important information about the installation and operation of this supervisory switch. This manual should be left with the owner/user of this equipment.

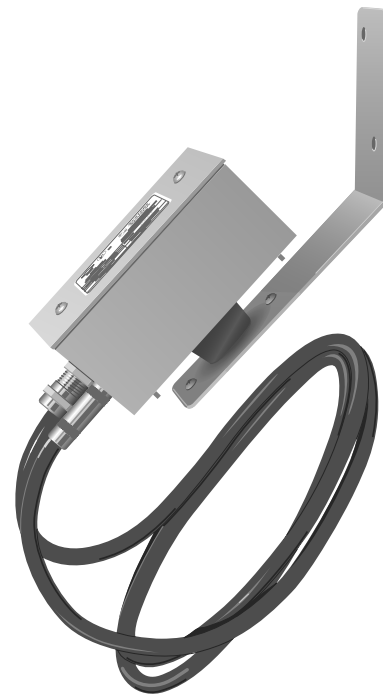
## General Information

The unit is intended for supervision of non-rising stem gate valves and other valves that cannot be monitored by conventional supervisory switches. Turning the valve wheel will pull the plug out of the jack and close a set of normally open contacts. A lockout will prevent reinsertion and require removal of the cover. Tamperproof screws are provided for the cover. Removal of cover, or cutting of cord or ground faults will cause an open circuit. The device should be wired to the trouble circuit of a fire alarm control panel.

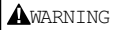
## Installation

1. Choose a location near the valve (safe from flooding) and mount the bracket to the wall.
2. Rotate the box on the bracket until the plug faces the valve. The plug must also point downward. Tighten the locknut on the pivot.
3. Turn the valve to the full-open position. Insert the plug into the jack. Tightly loop the 8-ft. waterproof cable through the valve wheel and back into the box through the cable clamp. Close valve to check that plug pulls out and then turn valve back to full-open position. Cut the cord to the minimum length required to make the connections within the box.
4. For all exterior applications, use 1/2" NPT, listed liquid-tight conduit connectors.
5. Wire the device as per the circuit diagrams shown (see Figures 2-5). Trim the unused black wire flush with the cable casing and cap the red wire of the cover tamper switch.
6. If a longer cable is required, use SJOW A 18-2, two conductor 18-gauge stranded rubber-jacketed cable.
7. Using the adhesive pad and wire tie provided, dress the wires

**Figure 1. PSP1A:**



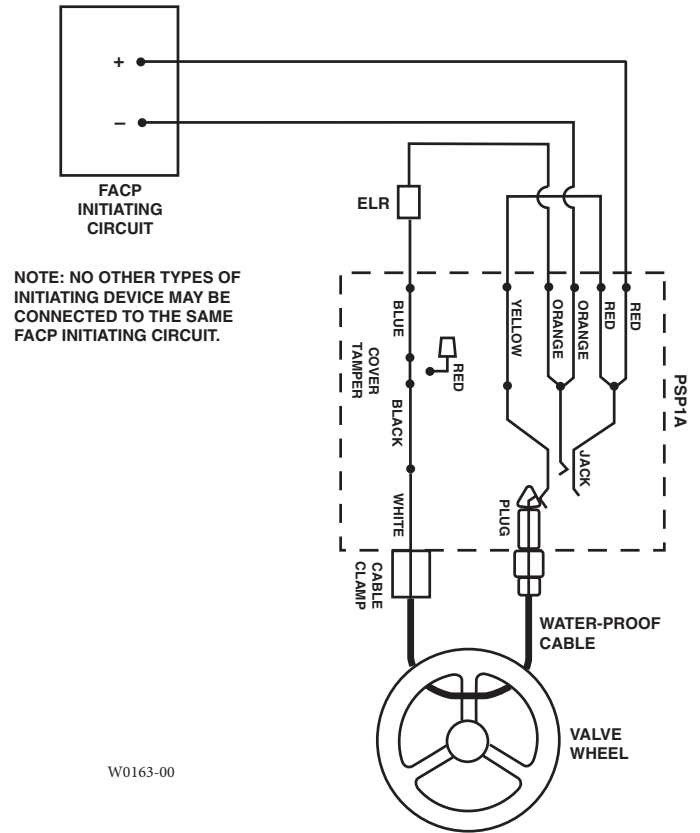
- away from the lock-out mechanism.
8. When installing the cover, make sure the O-rings are in place on the cover screws beneath the cover.



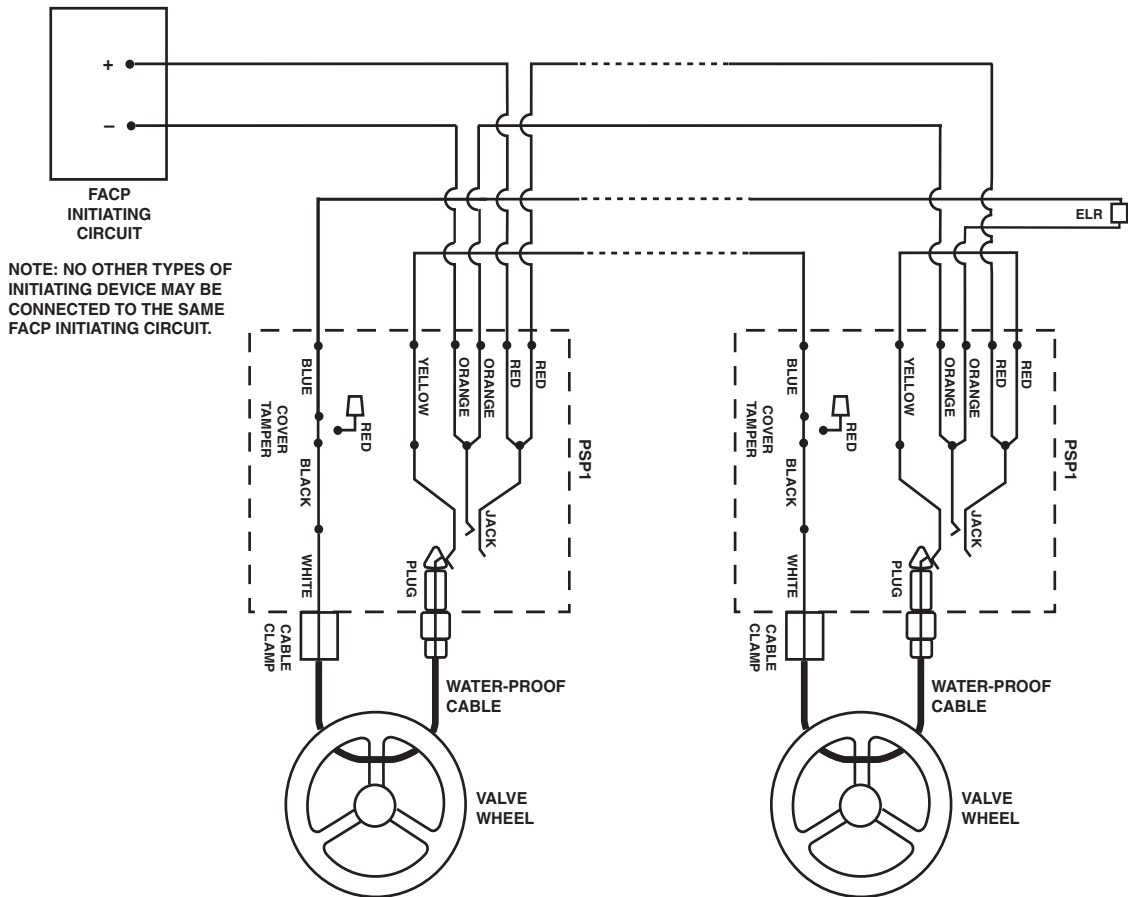
As stipulated by Factory Mutual and Underwriter's Laboratories, this unit is not intended or designed for ordinary usage. It is a special application device to be used for unusual conditions where no other approved or listed method of protection is available or practical, such as non-rising stem gate valves.

As this unit does not meet NFPA codes and standards (requiring restoration of the signal when the valve is positioned to normal), special attention should be given by the responsible parties to assure that the proper operation of this device is maintained. This device should only be restored to normal when the valve is in normal condition.

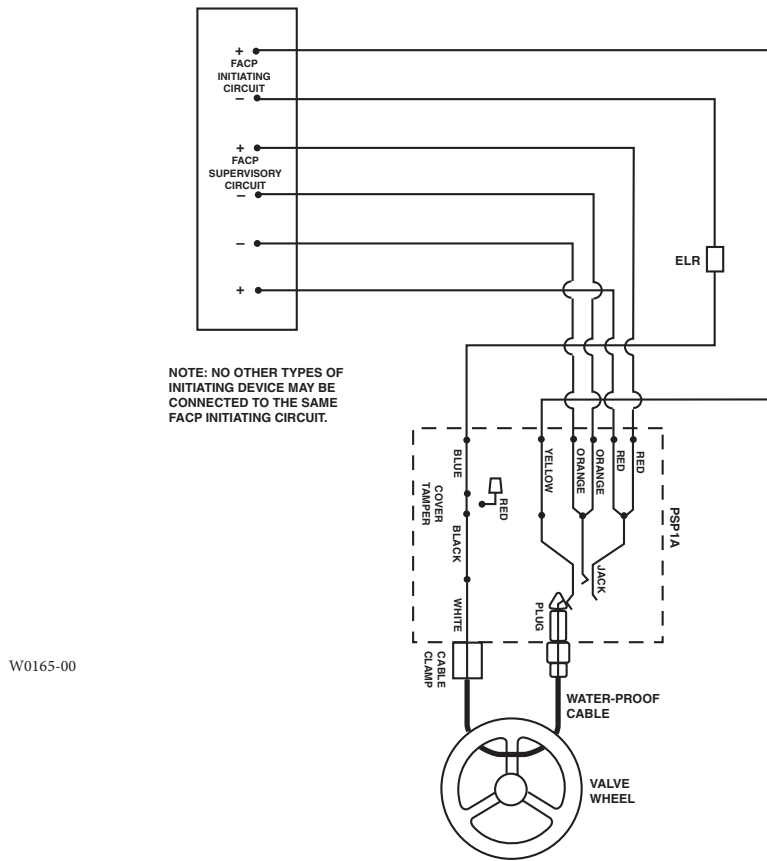
**Figure 2. Single device Class B:**



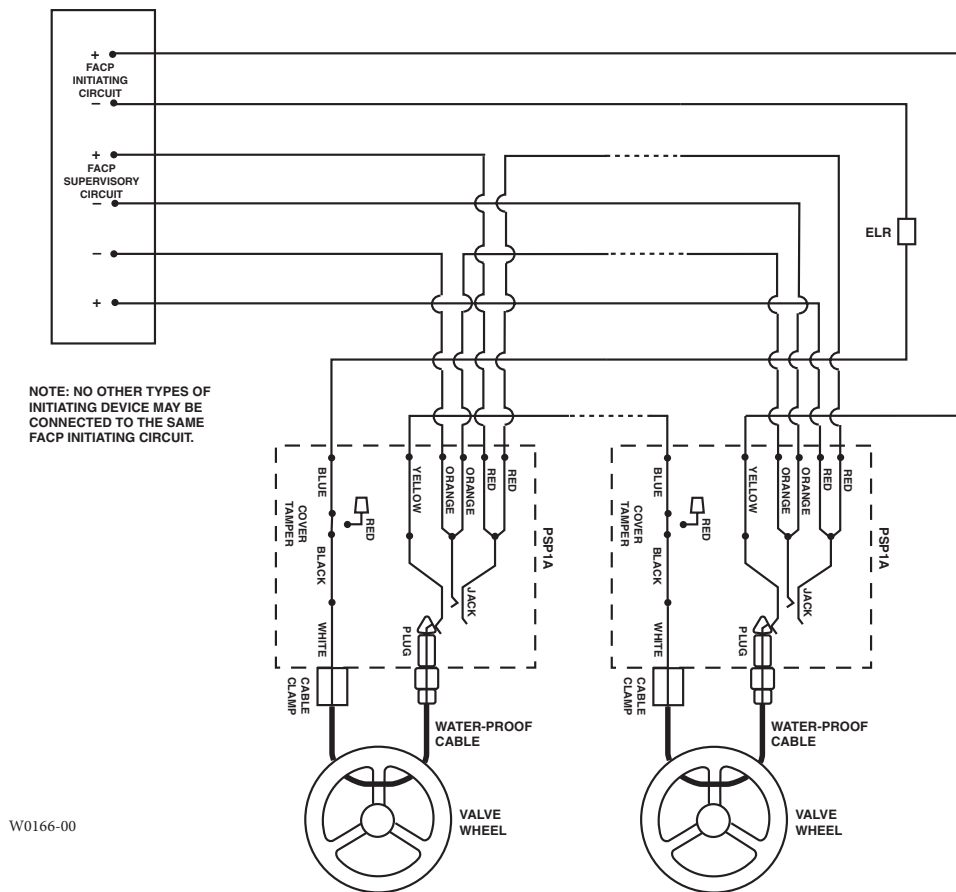
**Figure 3. Multiple devices Class B:**

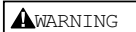


**Figure 4. Single device Class A:**



**Figure 5. Multiple devices Class A:**





WARNING

### **The Limitations of Supervisory Switch Alarm Devices**

1. Alarms generated by the actuation of the activation cord may not be received by a central station if telephone or other communication lines to the device are out of service, disabled, or open.
2. Supervisory switch alarm devices have a normal service life of 10-15 years.
3. Supervisory switches are not a substitute for insurance. Building owners should always insure property and lives being protected.

---

### **THREE-YEAR LIMITED WARRANTY**

SAFE SIGNAL warrants that the equipment herein shall conform to said descriptions as to all affirmation of fact and shall be free from defects of manufacture, labeling, and packaging for a period of three (3) years from the invoice date to the original purchaser, provided that representative samples are returned to SAFE SIGNAL for inspection. Upon a determination by SAFE SIGNAL that a product is not as warranted, SAFE SIGNAL shall, at its exclusive option, replace or repair said defective product or parts thereof at its own expense except that Purchaser shall pay all

shipping, insurance, and similar charges incurred in connection with the replacement of the defective product or parts thereof. This Warranty is void in the case of abuse, misuse, abnormal usage, faulty installation, or repair by unauthorized persons, or if for any other reason SAFE SIGNAL determines that said product is not operating properly as a result of causes other than defective manufacture, labeling, or packaging.