

INSTALLATION AND MAINTENANCE INSTRUCTIONS



WFDTN Vane-type Waterflow Detectors

SPECIFICATIONS

Contact Ratings:	Two sets of SPDT (Form C); 10 A @ 125/250 VAC \sim ; 2.5 A @ 24 VDC ---
Triggering Threshold Bandwidth (Flow Rate):	4 – 10 GPM
Static Pressure Rating:	375 PSI (Max.)
Dimensions, Installed:	WFDTN – 4in H x 3½ in W x 6¼ in D
Operating Temperature Range:	32°F to 150°F (0°C to 66°C)
Enclosure Rating:	WFDTN – NEMA Type 4, as tested by Underwriters Laboratories, Inc. (UL)
The WFDTN can be installed between 2x4 stud wall construction.	
U.S. Patent Number:	5,213,205

IMPORTANT

Please Read Carefully And Save

This instruction manual contains important information about the installation and operation of waterflow detectors. Purchasers who install waterflow detectors for use by others must leave this manual or a copy of it with the user. Read all instructions carefully before beginning.



The model WFDTN is a vane-type waterflow detector for use in wet-pipe fire sprinkler systems only. Vane-type waterflow detectors shall not be used as the sole initiating device in both deluge and preaction systems; waterflow detectors used in these types of systems may result in an unintended discharge caused by a surge, trapped air or a short retard time.

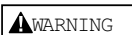

Installation must be performed by qualified personnel and in accordance with all national and local codes and ordinances.

Shock hazard: Disconnect power source before servicing. Serious injury or death could result.

Risk of explosion: Not for use in hazardous locations. Serious injury or death could result.

PRINCIPLES OF OPERATION

Vane-type waterflow detectors mount to water filled pipes in fire sprinkler systems. Waterflow in the pipe deflects a vane. Deflection of the vane produces a switched output, usually after a specified delay.

All WFDTNs have a pneumatically controlled mechanical delay mechanism. Delays do NOT accumulate; they reset if the flow of water stops or drops below minimum triggering flow rate before the entire delay has elapsed. All detectors will activate on a sustained flow of water of 10 gallons per minute (gpm) or greater downstream of the device.

COMPATIBLE PIPE TEES/RISERS

The WFDTN is supplied with 12 paddles. One paddle is provided for each size of the threaded, sweat or plastic tee. See Figure 1 and approximate tee depth chart. Each paddle has an indication that shows the pipe size and type of tee to be used with. The WFDTN also fits 1", 1½", and 2" Reliable riser manifolds when used with paddle tree P02-0032-300 (purchased separately).

APPROXIMATE TEE DEPTH REQUIREMENTS (SEE FIGURE 1)					
Tee Depth	Threaded	Sweat	CPVC NIBCO/ SPEARS (no insert)	CPVC SPEARxS (with insert)	CPVC/Tyco
1 x 1 x 1"	2 1/8"	1 3/4"	2 1/8"	2 15/32"	2 13/16"
1 1/4 x 1 1/4 x 1"	2 1/2"	2 1/8"	N/A	N/A	N/A
1 1/2 x 1 1/2 x 1"	2 3/4"	2 1/4"	3"	3"	N/A
2 x 2 x 1"	3 1/4"	2 3/4"	N/A	N/A	N/A

FIGURE 1. MOUNTING DIMENSIONS

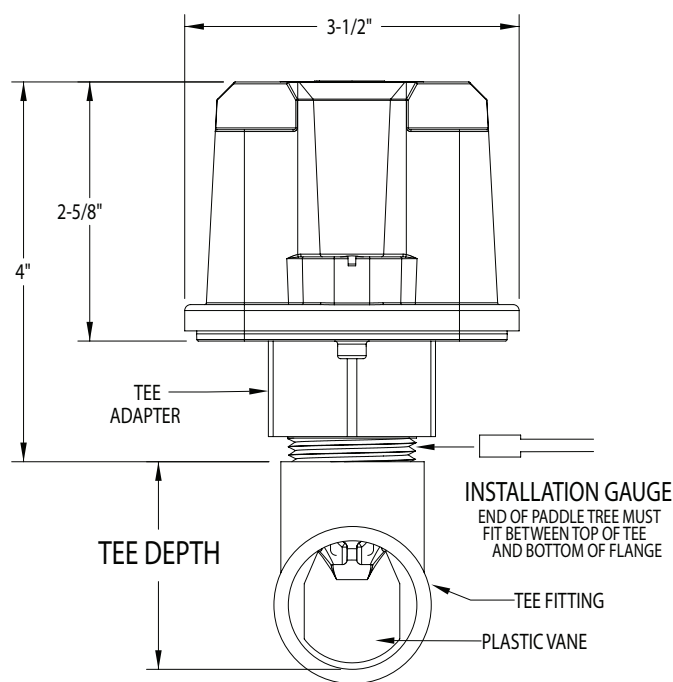

DESIGNED TO FIT WITHIN 2 X 4 STUD WALL CONSTRUCTION

W0390-00

INSTALLATION GUIDELINES

Before installing any waterflow alarm device, be thoroughly familiar with:

- NFPA 72: National Fire Alarm Code
- NFPA 13: Installation of Sprinkler Systems
- NFPA 25: Inspection, Testing, and Maintenance of Water-based Fire Protection Systems, Section 5.3.3.2
- NFPA 13D: Standard for 1 and 2 Family Dwellings and Manufactured Homes
- NFPA 13R: Standard for Multi-family Dwellings

Also, follow other applicable NFPA standards, local codes and the requirements of the authority having jurisdiction.

Failure to follow these directions may result in failure of the device to report a water-flow condition. Safe Signal is not responsible for devices that have been improperly installed, tested or maintained.

1. Mount the detector where there is adequate clearance for installation and removal and a clear view of it for inspection. See Figure 1 for mounting dimensions.
2. Locate the detector 6 to 7 feet above the floor to protect from accidental damage.
3. On horizontal runs, position the detector on top or side of the pipe. Do not mount it upside down because condensation may collect in the housing and impair the operation of the detector.

For vertical flow applications, mount detector on pipe where upflow conditions exist. Failure to do so may prevent unit from operating properly.

4. Mount detector at least 6 inches from a fitting which changes the direction of the waterflow, or no less than 24 inches from a valve or drain.
5. BE SURE DIRECTION-OF-FLOW ARROW AND DIRECTIONAL COVER MATCHES ACTUAL DIRECTION OF FLOW IN THE PIPE. See Figure 5.

FIGURE 2. ASSEMBLY DIAGRAM

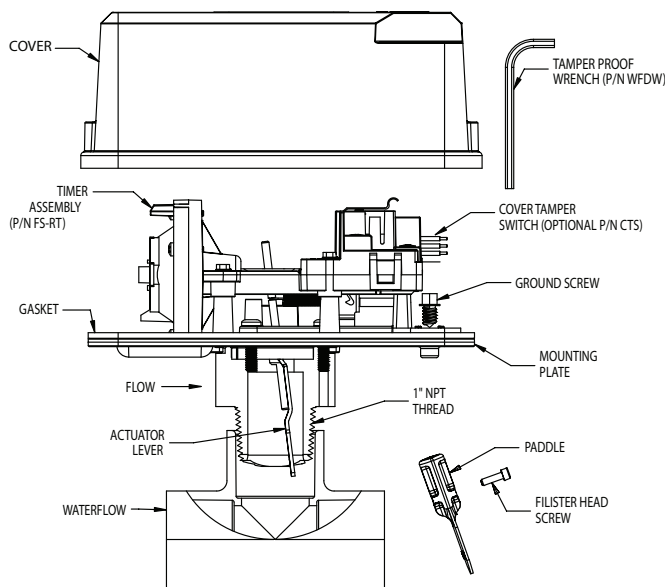

W0388-01

MOUNTING INSTRUCTIONS

1. The WFDN waterflow detector is designed to fit only the appropriate tee fitting.
NOTE: The outlet branch of tee must have a 1-inch NPT thread. Do not use a reducer to achieve the correct thread size. Failure to follow this instruction will result in failure of the detector to report a waterflow condition.
2. WFDN units are shipped without paddles mounted to the actuator. Select the correct size paddle for the type of tee being used. Align hole on stem of paddle with hole on actuator lever. Fasten together using a #4-40x³/₈-inch fillister head screw supplied in bag assembly. See Figure 2. Use only the screw provided with the unit. Drive screw head through hole in paddle until it seats to actuator lever surface. No washer is required. For paddle replacement refer to Maintenance section.

3. Carefully roll the vane opposite the direction of flow and insert through tee. Thread detector onto tee fitting and tighten with wrench. Use of thread sealant or tape is recommended. Use height gage (located at end of paddle tree) to ensure proper depth of detector on tee fitting. See Figure 1. Height gage must fit between top of tee fitting and under side of hex tee adapter. A gap between gage and tee adapter is acceptable. When correctly installed, the detector must face in the proper direction of waterflow and be aligned with the pipe, the provided directional cover illustrates flow direction for device.
4. Remove the cover. Move the actuator lever back and forth to check for binding. If the vane binds, remove the detector and correct the problem before proceeding.

CAUTION

Be sure the direction-of-flow arrow and directional cover point in the right direction, otherwise a waterflow condition will go unreported. See Figure 2 and Figure 5.



PREOPERATION TESTING

1. Fill the sprinkler system with water and check for leaks around the WFDN. If there is a leak, check to see that the fittings are tight. If leak persists, drain the system and remove the detector (see removal instructions under Maintenance). Check for damaged threads or cracked fitting. Reinstall the detector and check again for leaks. Do not proceed until all leaks have been stopped.
2. Connect an ohmmeter or continuity tester across (COM and B-NO) terminal switch contacts. The ohmmeter should show an open circuit, no continuity.
3. Deflect the actuator lever and hold it until the pneumatic delay shaft releases the switch buttons. The ohmmeter or continuity tester should show a short circuit after the delay has elapsed. If there is no delay, check the setting of the delay adjustment dial.

FIELD WIRING

WARNING

High Voltage. Electrocutation Hazard. Do not handle live AC wiring or work on a device to which AC power is applied. Doing so may result in severe injury or death.

When utilizing switches at voltages greater than 74VDC  or 49VAC  means to provide all-pole disconnection must be incorporated in the fixed wiring, such as a circuit breaker.

1. The WFDN has two SPDT switches. Switch contacts (COM and B-NO) are closed when water is flowing and open when water is not flowing. Connect the switches as shown in Figure 6 depending on the application.
2. When connected to a listed sprinkler/fire alarm control panel, the initiating circuit must be unable to be silenced.
3. A ground screw is provided with all units. When grounding is required, clamp wire with screw in hole located between conduit entrance holes. See Figure 3.
4. Use proper waterproof conduit fittings where required.

FIGURE 3.

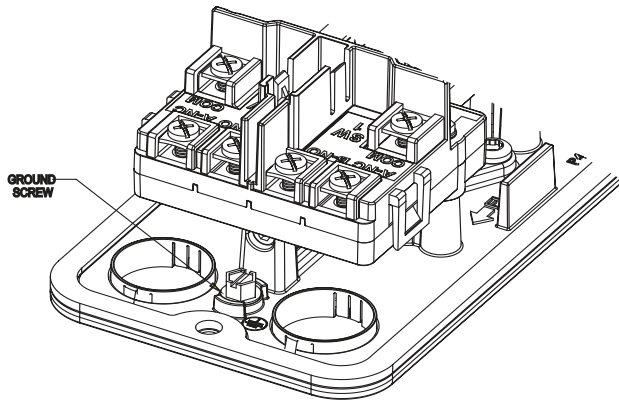

W0383-01

MECHANICAL DELAY ADJUSTMENT

The pneumatic delay is preset at approximately 30 seconds at the factory. To adjust the delay, turn the adjustment dial on the delay mechanism. Turn clockwise to increase the delay, counterclockwise to decrease the delay. Delay can be adjusted over a range from 0-90 seconds maximum. See Figure 4. As a point of reference when setting time delay in dark environments the notch in the dial indicates an approximate 30 second time delay and the larger of the three tabs indicates an approximate 60 second time delay.

NOTE: Set the delay to the minimum required to prevent false alarms due to flow surges.

After extended service, parts of the detector may become worn reducing the time delay and causing false alarms. If this happens, increase the delay. If the delay is already at maximum, replace the mechanical delay assembly. Refer to Maintenance section for ordering replacement parts.

OPERATIONAL TESTING

Always notify a central station monitoring waterflow alarms before repairing, maintaining or testing waterflow alarm devices.

1. Replace the cover and tighten the security screws with the tamper proof wrench. Store the wrench in a secure place.
2. Open the inspector's test valve and time how long it takes for the detector to indicate a flow condition. The detector should remain activated until the inspector's test valve is closed. Air pockets in the sprinkler system may increase the apparent time delay.

FIGURE 4. DELAY ADJUSTMENT DIAL

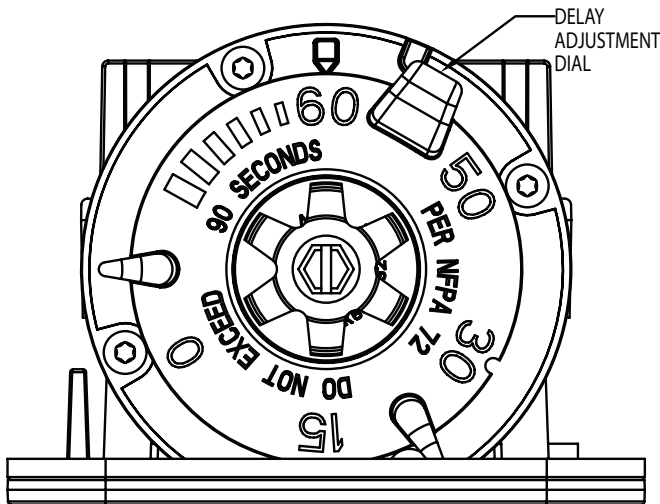

NOTE: RETARD TIME MAY EXCEED 90 SECONDS. ADJUST AND VERIFY THAT TIME DOES NOT EXCEED 90 SECONDS. NUMBER ON DIAL IS APPROXIMATE TIME DELAY IN SECONDS

W0385-00

MAINTENANCE

To prevent accidental water damage, control valves should be shut tightly and the system completely drained before waterflow detectors are removed or replaced.

Inspect detectors in accordance with applicable NFPA codes and standards and/or the authority having jurisdiction for leaks and replace if leaks occur. Test detectors at least quarterly as described under Operational Testing to insure proper operation. Test more often if required by the authority having jurisdiction.

Under normal conditions Safe Signal waterflow detectors should provide years of trouble-free service. However, if the delay mechanism becomes faulty, a replacement kit is available. To replace the delay mechanisms, request Part No. FS-RT. Complete instructions are enclosed with replacement parts. The delay mechanism can be easily replaced without removing the detector from the pipe or draining the pipe. If damage occurs to paddle, order replacement kit, request Part No. PRK9. Refer to procedure below for removal of detector on pipe. Do not repair or replace any other waterflow detector components in the field. If any other part of the detector does not perform properly, replace the entire detector. Failure to follow this instruction may result in failure of the detector to report a waterflow condition.

Proceed as follows to remove a detector.

1. Drain the pipe.
2. Turn off electrical power to the detector, and then disconnect wiring.
3. Unscrew WFDTN from tee fitting.
4. Lift detector clear of pipe.

CAUTION

If a vane breaks off in a pipe, find and remove it. Failure to do so may restrict the proper flow of water to part of the sprinkler system.

FIGURE 5. DIRECTIONAL COVER

NOTCHED COVER INDICATES FLOW DIRECTION AT A DISTANCE FROM MULTIPLE VIEWING ANGLES

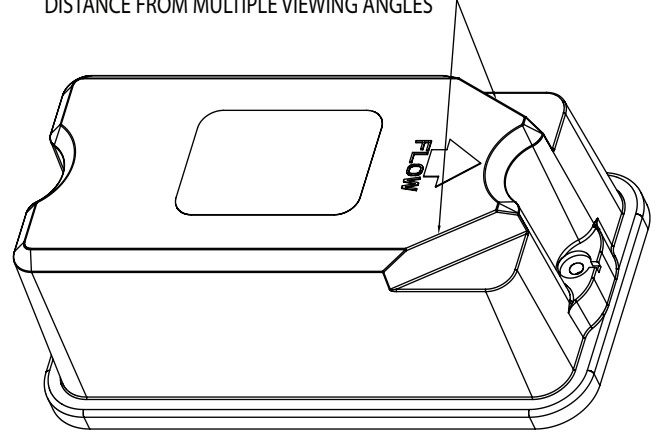

W0382-00

FIGURE 6. FIELD WIRING

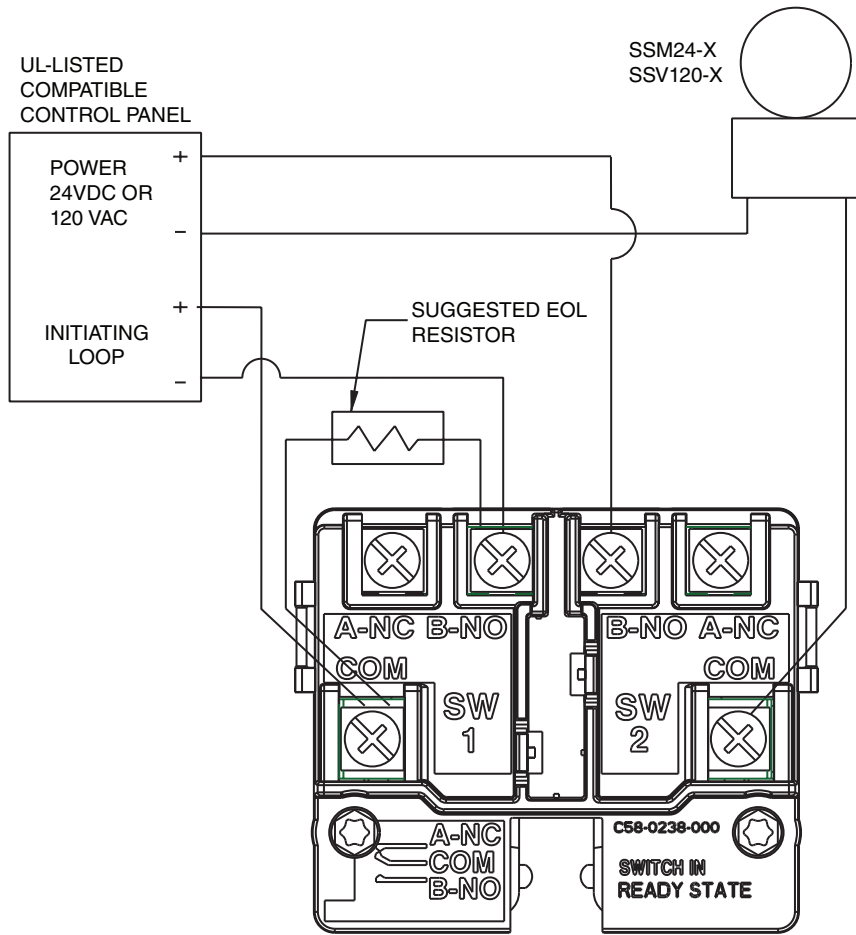

NOTE: COMMON AND B-NO CONNECTIONS WILL CLOSE WHEN VANE IS DEFLECTED, I.E., WHEN WATER IS FLOWING. DUAL SWITCHES PERMIT APPLICATIONS TO BE COMBINED ON A SINGLE DETECTOR.

CONTACT RATINGS	
125 / 250 VAC	10 AMPS
24 VDC	2.5 AMPS

SCHEMATIC OF INDIVIDUAL SWITCH IN "NO WATERFLOW" CONDITION

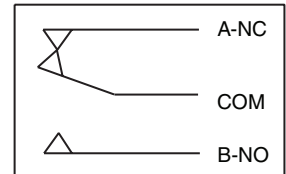

BREAK WIRE AS SHOWN FOR SUPERVISION OF CONNECTION. DO NOT ALLOW STRIPPED WIRE LEADS TO EXTEND BEYOND SWITCH HOUSING. DO NOT LOOP WIRES.

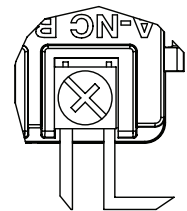

W0393-02



THE LIMITATIONS OF WATERFLOW ALARM DEVICES

- Waterflow detectors may not work or operate properly if sprinkler piping being monitored is plugged with pipe scale, mud, stones or other foreign material. Sprinkler systems should be checked regularly for such blocking material, following the instructions in Chapter 5 of NFPA Standard 13A.
- Alarms generated by the activation of waterflow detectors may not be received by a central station if telephone or other communication lines to the detector are out of service, disabled, or open.
- Vane-type waterflow detectors have a normal service life of 10-15 years. Hard water systems, however, may substantially reduce waterflow detector service life.
- Waterflow detectors are not a substitute for insurance. Building owners should always insure property and lives being protected by sprinkler systems.
- If valves controlling the water supply to a sprinkler system are closed, vane-type waterflow detectors will not work. All valves controlling a sprinkler water supply should be sealed or locked in the normally open position. The normally open position should be monitored by a sprinkler supervisory switch.

THREE-YEAR LIMITED WARRANTY

SAFE SIGNAL warrants that the equipment herein shall conform to said descriptions as to all affirmation of fact and shall be free from defects of manufacture, labeling, and packaging for a period of three (3) years from the invoice date to the original purchaser, provided that representative samples are returned to SAFE SIGNAL for inspection. Upon a determination by SAFE SIGNAL that a product is not as warranted, SAFE SIGNAL shall, at its exclusive option, replace or repair said defective product or parts thereof at its own expense except that Purchaser shall pay all

shipping, insurance, and similar charges incurred in connection with the replacement of the defective product or parts thereof. This Warranty is void in the case of abuse, misuse, abnormal usage, faulty installation, or repair by unauthorized persons, or if for any other reason SAFE SIGNAL determines that said product is not operating properly as a result of causes other than defective manufacture, labeling, or packaging.