

EPS40 Series and EPS120 Series Supervisory Pressure Switches

3825 Ohio Avenue, St. Charles, Illinois 60174
 1-800-SENSOR2, FAX: 630-377-6495
 www.systemsensor.com

SPECIFICATIONS

Contact Ratings:	10 A, 1/2 HP @ 125/250 VAC ~
	8A @ 125/250 VAC ~ (LPCB ONLY)
	2.5A @ 6/12/24 VDC - - -
Overall Dimensions:	See Figure 1
Operating Temperature Range:	-40°F to +160°F
Maximum Service Pressure:	EPS40-1, EPS40-2: 300 PSI
	EPS120-1, EPS120-2: 300 PSI
Adjustment Range:	EPS40-1, EPS40-2: 10-100 PSI
	EPS120-1, EPS120-2: 10-200 PSI
Enclosure Rating:	UL 4x — Indoor or Outdoor Use
	NEMA 4 — Indoor or Outdoor Use
	IP54
Approximate Differential:	EPS40-1, EPS40-2: 3 PSI at 10 PSI
	6 PSI at 100 PSI
	EPS120-1, EPS120-2: 3 PSI at 10 PSI
	9 PSI at 200 PSI

IMPORTANT

Please Read Carefully and Save

This instruction manual contains important information about the installation and operation of supervisory pressure switches. Purchasers who install switches for use by others must leave this manual or a copy of it with the user.

Read all instructions carefully before installation, following only those instructions that apply to the model you are installing.

Before installing any alarm device, be thoroughly familiar with:

- NFPA 72: National Fire Alarm Code
- NFPA 13: Installation of Sprinkler Systems
- NFPA 25: Inspection, Testing, and Maintenance of Water-based Fire Protection Systems
- NFPA 13D: Standard for 1 and 2 Family Dwellings and Manufactured Homes
- NFPA 13R: Standard for Multi-family Dwellings

Other applicable NFPA standards, local codes, and the requirements of the authority having jurisdiction.

Failure to follow these directions may result in failure of the device to report an alarm condition. System Sensor is not responsible for devices that have been improperly installed, tested, or maintained.

CAUTION

Do not use in potentially explosive atmospheres. Do not leave unused wires exposed.

OPERATION

As pressure changes, a diaphragm actuates 1 or 2 snap action switches. The pressure switch actuation is determined by adjustment settings.

INSTALLATION

1. Remove Cover
Cover is held on by two screws.
2. Mounting the Switch
The device is designed to be mounted in the upright position; side mounting is also acceptable. Locate it where vibration, shock, and mechanical loading are minimal. Refer to piping diagram above (Fig. 2 and 3).
 - a. Mount the device directly to the line via the 1/2" NPT pressure connection. The use of teflon pipe sealant tape is recommended. Be sure the fitting is tight enough to prevent leaks.
 - b. Apply tightening torque to the black plastic hex portion of the device.

WARNING

High voltage. Electrocutation hazard. Do not handle live AC wiring or work on a device to which AC power is applied. Doing so may result in severe injury or death. When utilizing switches at voltages greater than 74 VDC - - - or 49 VAC ~ , means to provide all-pole disconnection must be incorporated in the field wiring, such as a circuit breaker.

3. Wire the device in accordance with the National Electrical Code. Two 7/8" diameter conduit connection holes have been provided in the mounting plate to accept standard 1/2" conduit fittings (one is removable knock-out type). If a NEMA 4/UL 4x (waterproof unit) is required, waterproof flexible metallic conduit and appropriate conduit fittings must be used. Recommended connectors are Thomas and Betts PN 5332 (180° coupling), PN 5352 (90° coupling), and PN 5262 seal ring.
4. Connect wiring to terminals (see Figure 4 and Table 1).

Adjustments to Factory Settings

FIGURE 1. PRESSURE SWITCH BASIC DIMENSIONS:

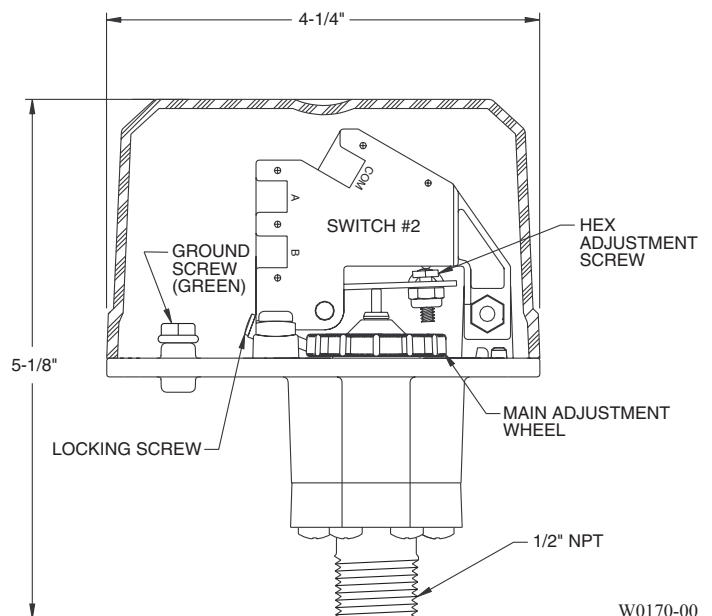

W0170-00

FIGURE 2. TYPICAL PIPING DIAGRAM FOR EPS40-1, EPS40-2

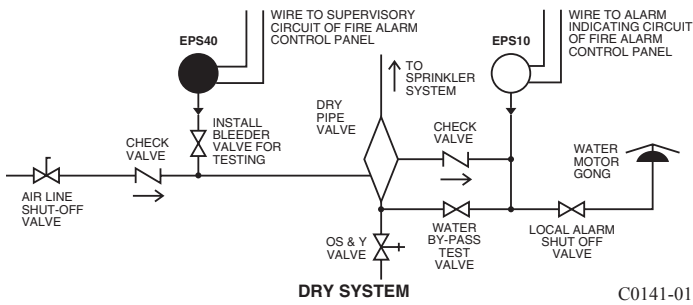

FIGURE 3. TYPICAL PIPING DIAGRAM FOR EPS120-1, EPS120-2

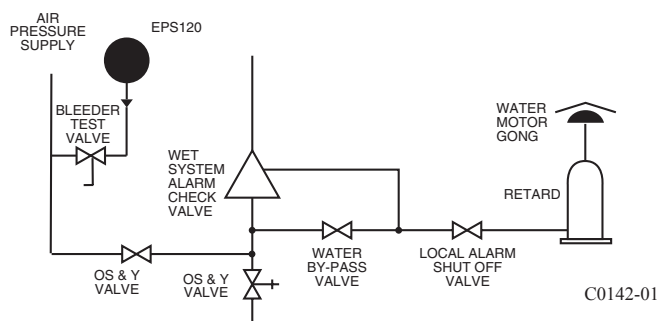

TABLE 2.

MODEL	FACTORY SETTINGS (PSI)		
	FALL SW2 (LOW SWITCH)	NOMINAL	RISE SW1 (HI SWITCH)
EPS40-1	30 ±1.5	40	-
EPS40-2	30 ±1.5	40	50 ±2.5
EPS120-1	101.5 - 112.5	115	-
EPS120-2	101.5 - 112.5	115	117.5 - 128.5

SINGLE-SWITCH MODEL – EPS40-1 AND EPS120-1

1. Install pressure switch as stated in “INSTALLATION” portion of instruction manual. Attach pressure test source to system.
2. Back off locking screw (see Fig. 4) to allow main adjustment wheel to rotate freely.
3. Test the switch for the set point by introducing 40 PSI pressure from the pressure test source for the EPS40-1 (115 PSI for the EPS120-1). Decrease pressure slowly until the switch trips. Rotate main adjustment wheel, Figure 5, (counterclockwise to increase pressure) and retest by first introducing a higher pressure than desired and slowly reducing pressure until the switch trips. Repeat process until switch trip point is at desired pressure setting. Each number represents an approximate trip point change of 1.8 PSI for the EPS40-1 and 6.6 PSI for the EPS120-1. For each 1/2 rotation of the adjustment wheel, the trip point setting changes by approximately 11 PSI for the EPS40-1 and 40 PSI for the EPS120-1.

FIGURE 4. SWITCH LOCATION:

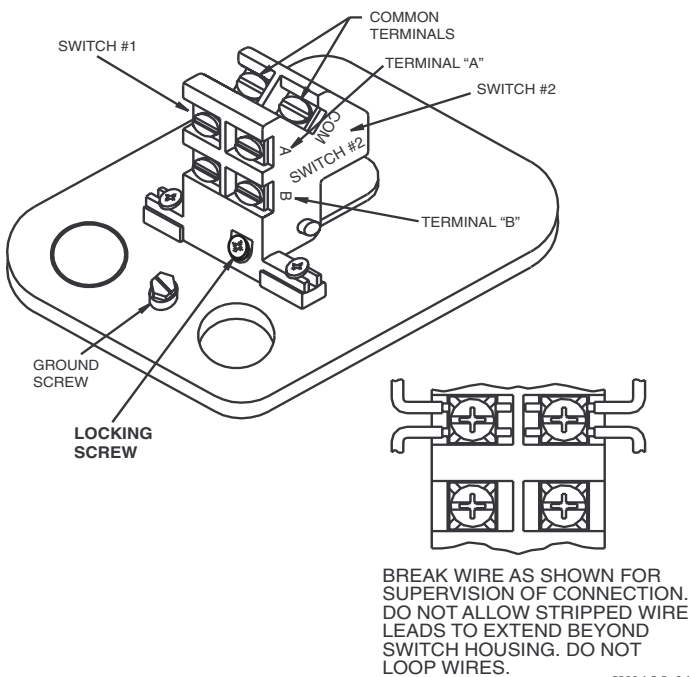

4. Retest the set point several times to ensure accuracy of setting.
 5. Re-seat locking screw.
- DUAL-SWITCH MODEL – EPS40-2 AND EPS120-2**
1. Install pressure switch as stated in “INSTALLATION” portion of instruction manual. Attach pressure test source to system.
 2. Back out the locking screw (see Fig. 4) to allow main adjustment wheel to turn freely.
 3. **Option 1: Adjust nominal pressure setting without affecting PSI window.**
 - a) Adjust main adjustment wheel (see Fig. 5) to desired setting using pressure source (i.e., valve or air maintenance device).
 - b) Turn main adjustment wheel counterclockwise to increase (see arrow on mounting base) or clockwise to decrease pressure. Each number on main adjust wheel represents an approximate window shift of 1.8 psi for EPS40-2 and 6.6 psi for EPS120-2. For each 1/2 rotation of the adjustment wheel the window changes by approximately 11 psi for EPS40-2 and 40 psi for EPS120-2.
 - c) Retest the set point several times to ensure the accuracy of the setting.
 - Option 2: Adjust pressure window size and nominal setting of pressure window.**
 - a) Adjust main adjustment wheel (see Fig. 5) until high switch (SW1) trips at desired pressure using pressure test source (valve or air maintenance device).
 - b) Refer to step B from Option 1.
 - c) Decrease pressure until the low switch trips (SW2).
 - d) Adjust 1/4" low pressure hex head nut (see Fig. 5) to either increase (counterclockwise) or decrease (clockwise) the window size (the low switch will be affected).
 - e) The approximate sensitivity of the hex screw adjustment: 1/2 turn = 5 psi. A maximum of 30 psi is attainable.
 4. Retest the set points several times to ensure the accuracy of the settings, and adjust as necessary.
 5. Re-seat locking screw.

NOTE: EPS40 models are able to be set to a range within 8-100psi only when used with Victaulic series 768 and 769 FireLock NXT valves pre-set for use with low pressure actuators. When used on Victaulic series 768 and 769 FireLock NXT all units must be 100% tested to verify pressure setting. Both the main adjustment wheel and low pressure adjusting screw (See Figure 5) need to be customer set and tested to insure proper functionality. For pressure setting instructions refer to Installation section for dual switch models in this manual.

TABLE 1. ELECTRICAL CONNECTIONS (REFERENCED AT FACTORY SETTINGS):

MODELS EPS40-1, EPS120-1	MODELS EPS40-2, EPS120-2
<p>SWITCH AT NORMAL SYSTEM PRESSURE</p> <pre> B --- COM --- A --- </pre> <p>SWITCH AT TRIP POINT</p> <pre> B --- COM --- A --- </pre> <p>SWITCH 1</p>	<p>SWITCHES AT LOW TRIP POINT</p> <pre> B --- COM --- A --- </pre> <p>SW1</p> <pre> B --- COM --- A --- </pre> <p>SW2</p> <p>SWITCHES AT NORMAL SYSTEM PRESSURE</p> <pre> B --- COM --- A --- </pre> <p>SW1</p> <pre> B --- COM --- A --- </pre> <p>SW2</p> <p>SWITCHES AT HIGH TRIP POINT</p> <pre> B --- COM --- A --- </pre> <p>SW1</p> <pre> B --- COM --- A --- </pre> <p>SW2</p>

W0185-01

W0186-00

NOTE: The sensor assembly is not field replaceable. Do not attempt to disassemble these parts. If you have any questions, consult System Sensor. System Sensor recommends careful consideration of the following factors when specifying and installing Alarm and Supervisory Pressure Switches. Always refer to the Installation and Maintenance Instruction for specific recommendations on individual devices before installing the unit.

- Electrical ratings stated in literature and on nameplates should not be exceeded.
- Overload on switch can cause failure on the first cycle. Always wire devices according to national and local electrical codes.
- Install units away from shock and vibration. Proper electrical fittings should be used to prevent moisture from entering the enclosure via the conduit.
- Test all devices for proper operation after initial installation. Perform preventive maintenance and periodic testing as required by the applicable NFPA standards but not less than bimonthly.
- Install a back-up control for all critical applications where control failure could endanger life or property. A backup control to serve as a high or low limit control is especially recommended for applications where a runaway condition could result.
- Do not mount unit where ambient temperatures will exceed published limits.
- Avoid impact or mechanical loading.

FIGURE 5. ADJUSTMENTS (DUAL-SWITCH MODEL SHOWN):

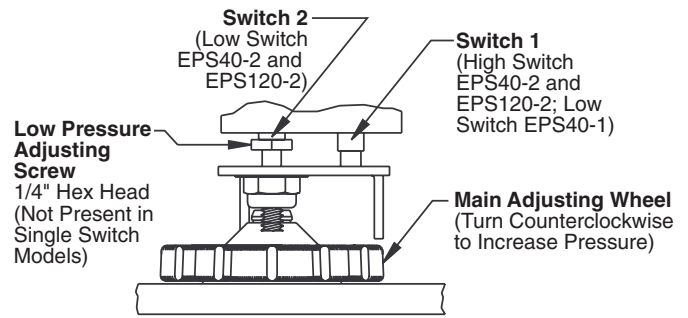

NOTE: Each 1/2 turn of Low Pressure adjusting screw adjusts pressure approximately 5 psi. Turn counter clockwise to increase pressure. Turn clockwise to decrease pressure. Each 1/2 turn of High Pressure adjusting wheel adjusts pressure 11 psi on the EPS40-2 and 40 psi on the EPS120-2.

W0144-02

Please refer to insert for the Limitations of Fire Alarm Systems

THREE-YEAR LIMITED WARRANTY

System Sensor warrants its enclosed pressure switch to be free from defects in materials and workmanship under normal use and service for a period of three years from date of manufacture. System Sensor makes no other express warranty for this pressure switch. No agent, representative, dealer, or employee of the Company has the authority to increase or alter the obligations or limitations of this Warranty. The Company's obligation of this Warranty shall be limited to the repair or replacement of any part of the pressure switch which is found to be defective in materials or workmanship under normal use and service during the three year period commencing with the date of manufacture. After phoning System Sensor's toll free number 800-SENSOR2 (736-7672) for a Return Authorization number, send defective units postage prepaid to: Honeywell, 12220 Rojas

Drive, Suite 700, El Paso TX 79936, USA. Please include a note describing the malfunction and suspected cause of failure. The Company shall not be obligated to repair or replace units which are found to be defective because of damage, unreasonable use, modifications, or alterations occurring after the date of manufacture. In no case shall the Company be liable for any consequential or incidental damages for breach of this or any other Warranty, expressed or implied whatsoever, even if the loss or damage is caused by the Company's negligence or fault. Some states do not allow the exclusion or limitation of incidental or consequential damages, so the above limitation or exclusion may not apply to you. This Warranty gives you specific legal rights, and you may also have other rights which vary from state to state.